

A stylized, 3D-rendered blue figure of a person in a dynamic, athletic pose, possibly performing a backflip or a similar movement. The figure is composed of smooth, rounded shapes and has a slight shadow beneath it, giving it a sense of depth and movement. It is positioned behind the main text.

Physiotherapy
in ALS

The daily Life Physiotherapy and Assistance

Renzo Deambrogio
Fiorella Nalin
Helena Pastore
Mario Tinisella

Published by **ASRIM**
Association de la Suisse Romande et l'Italie
contre les Myopathies

Editoriaal

Uitgever:
ASRIM - Association de Suisse Romande et Italie contre les Myopaties
Chemin de la Traverse 12
Boite postale 179
CH 1170 Aubonne T

el: 02/80887411
Fax: 02/8088111
E mail: ASRIM@asrim.ch
Web: <http://www.asrim.ch>
C.C.P. 10.15136-6

Translation: Karla Heylen ALS Liga

ALS Liga België vzw

Nationaal secretariaat

Campus Sint Rafaël, Blok H, 4th Floor
Kapucijnenvoer 33 B/1
B-3000 Leuven
Belgium

Tel.: +32(0)16/23.95.82
Fax.: +32(0)16/29.98.65

info@alsliga.be
www.ALSLIGA.be

Opening hours:
Mon, Tues., Thurs. & Fri. from 09.00 till
16.00
Wed: closed

Please make an appointment before
visiting.

Coördinator:
0496/46 28 02

THE DAILY LIFE, PHYSIOTHERAPY AND ASSISTANCE

Door Renzo Deambroglio
Fiorella Nalin
Elena Pastore
Mario Tinisella

Summary:	Foreword	p 3
	Joint Mobility	p 4
	Avoid Side Effects	p 4
	Active Mobility	p 4
	The shoulders	p 5
	The elbows	p 7
	The wrists	p 8
	The fingers	p 9
	The hips	p 10
	The knees	p 11
	The ankles	p 11
	The head	p 12
	The chest	p 13
	Active, Assisted and passive motion	p 14
	The shoulders	p 15
	The elbows	p 16
	The wrists	p 17
	The fingers	p 17
	The hips	p 19
	The feet	p 21
	The head	p 22
	The chest	p 23
	Mouth- and Facial Mobility	p 23
	Good posture	p 24
	Daily life,	p 26
	Devices: what are they, what do they do?	p 26
	Devices for walking and other mobility equipment	p 26
	Support sole from Codivilla	p 26
	Canes	p 27
	The walking aid	p 28
	The wheelchairs	p 29
	Tools for walking stairs	p 30
	Changes in posture from or by the patient	p 32
	Devices for the bathroom	p 34
	Resources for feeding and dressing	p 35
	Resources for communication	p 36

Foreword

This publication is intended for ALS patients, their relatives and care givers.

ALS causes a progressive loss of muscle strength with a sense of general fatigue. The simplest and daily movements are difficult and painful; such as washing, manipulating buttons, cutting meat,, opening a door, climbing stairs, crossing longer distances, and so on. The daily life of the patient gets increasingly difficult as the muscles become weaker during the progress of the disease. It is not good - it may even be harmful - to strive to strengthen the muscles through intense physical exercises. This can lead to early weakening and increase of difficult function of an already compromised ability, namely the symptoms stay the same.

The well-founded objectives of re-adaptation are on the opposite:

*** Limiting of secondary lesions, caused by the loss of mobility.

The daily movement exercises and optimal posture when sitting, lying, etc. reduce the most common effects of immobility, such as tendon contractions, joint stiffness, or dislocation of the shoulder caused by poor posture.

*** Advising of assistance and devising a plan to maintain autonomy as long as possible. It sometimes only requires simple means, the use of certain instruments, tools that enable the performance of certain activities. For example: adding more volume to the handle of the cutlery, it also simplifies its use. Use of a wheelchair makes covering great distances possible, etc.

*** Educating caregivers and surroundings to enable an efficient handling of the patient.

Changing postures and locations are critical moments in the daily life of the ALS patient. If you know how to deal with these situations it will take less effort and you avoid causing injuries.

The purpose of this booklet is to provide general guidance in your choice of physical therapy programs, adapted to the degree of weakening of the muscles. It also gives information on existing means concerning the daily life activities, about assisting a non-autonomous person and about improving his/her physical comfort.

The physical therapy programs and the regulations for assistance should of course be custom-made to the person and demand a strict evaluation and guidelines for optimal care, which are given by qualified personnel.

The manual consists out of two parts:

The first part discusses the goal of physiotherapy. The second part suggests a planning and objectives to help coping with the general problems of daily life.

The authors

Renzo Deambroglio

Fiorella Nalin

Helena Pastore

Mario Tinisella

Therapists Rehabilitation; "Fondation Salvatore Muggeri, Clinique du travail et de réadaptation, IRCSS, Veruno, NO."

The authors of this book are part of the group of physiotherapists trained in the Medical Centre Veruno to help ALS patients.

After years of only having applied Physiotherapy we discovered that this was only a slight relief in comparison to the huge and very complex problem of the pathology. The accompaniment and assistance of the ALS patient requires from the caregiver moments of punctual evaluations from the event, recommendations of tools and supporting devices to ensure autonomy, the organization of physiotherapy treatments, and the preparing of relatives in assisting the sick with daily care.

The theme of this book is being the "index card" of functional assessment, established and proven by the group in the course of many years.

Joint Mobility

What's the use of Physiotherapy in ALS?

Avoiding Side Effects.

The immobility can cause muscle contractions, weakness and stiffness of the joints, and progressive pain. Take a moment to build a daily program either active with help or passive. This should be achieved by maintaining effective postures, lying, sitting or standing. This way many problems can be reduced. Each physiotherapy program must take into account two fundamental rules: Do not exceed the fatigue threshold, do not cause the pain to increase.

When to stop the activities?

When fatigue occurs and gives signals like

- Cramps
- Tendon fasciculation
- Feeling of heavy legs and arms

in these cases, one must stop the exercises.

If the patient, after a of 20 minutes break, cannot regain his starting position, it must be understood that the activity undertaken is too heavy. Taking into account the above rules and performed in moderation even swimming, cycling or walking are no inadvisable activities.

Active motility

How do perform the exercises?

The proposed exercises concern patients with sufficient strength. They aim to make **the muscles to work effectively**, to keep them flexible and tonic and **the joints fully to involve**. The exercises may be performed **while sitting up** (exhausting) or **decumbent** (less tiring) depending on the degree of tolerable fatigue, without bad consequences, such as described in the previous paragraph, occurring. It is sometimes good to repeat the exercises, to perform them slowly, to obtain a maximum of joint motion, and maintain for a few moments the relaxation of muscles and ligaments before slowly returning to the starting position. It might be a good idea to schedule the program in such a way that there will be two sessions a day.

The shoulders

Exercise 1

- a * Sitting up, arms next to the body, feet on the ground.
- b * Lift stretched arms upward, with palms directed downwards.
- c * Lift stretched arms up.
- d * Return to start position.

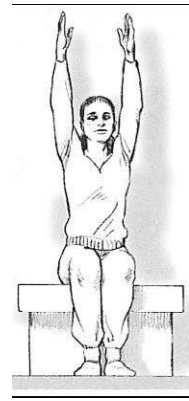

exercise 2

- a * Lying down, arms next to the body.
- b * Lift arms up, palms facing forward.
- c * Lift arms further and bring them alongside the head;
- d * Return to the start position.

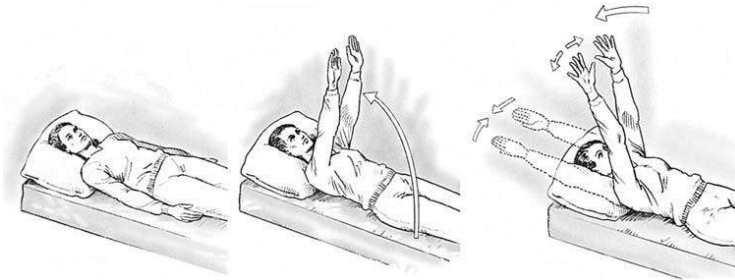

exercise 3

- a * Sitting up, arms next to the body, feet on the ground.
- b * Lift stretched arms up and facing outward, with palms facing upwards.
- c * Bring arms further stretched upwards till above the head.
- d * Return to start position.

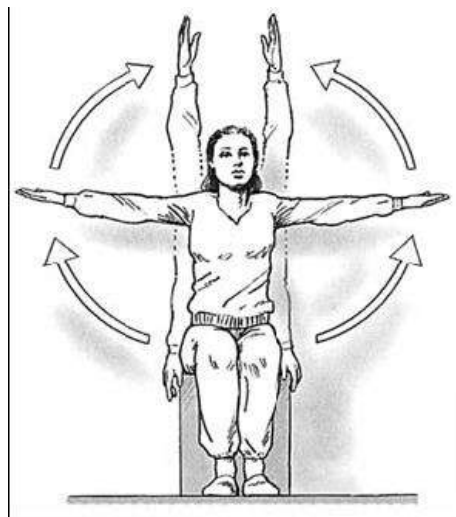

exercise 4

- a * Lying down, arms next to the body
- b * Stretch arms sideways, palms facing upwards.
- c * Move the outstretched arms further till above the head.
- d * Return to start position.

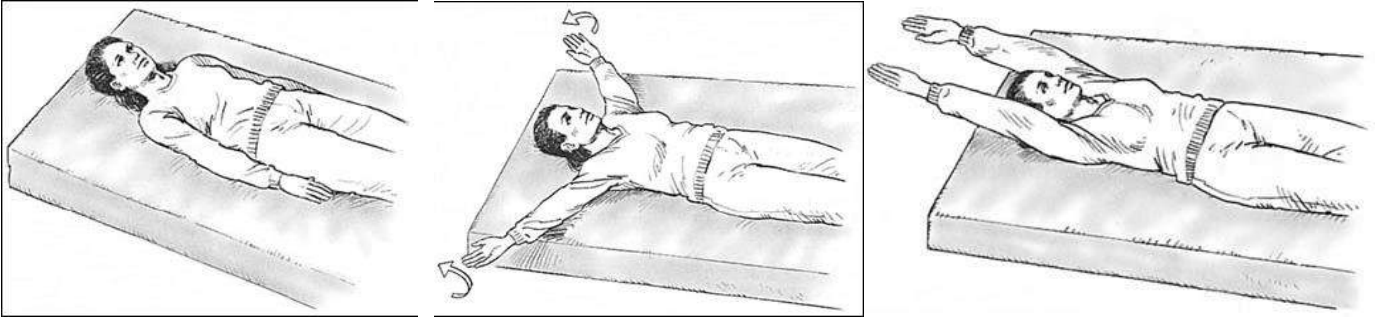
**exercise 5**

- a* Lying down, stretch arms sideways up to 90 ° from the body.
- b * Fold the elbows at 90 °, turn palms forward.
- c * Lower the forearms forward onto the bed, while keeping elbows bent.
- d * Return to start position.

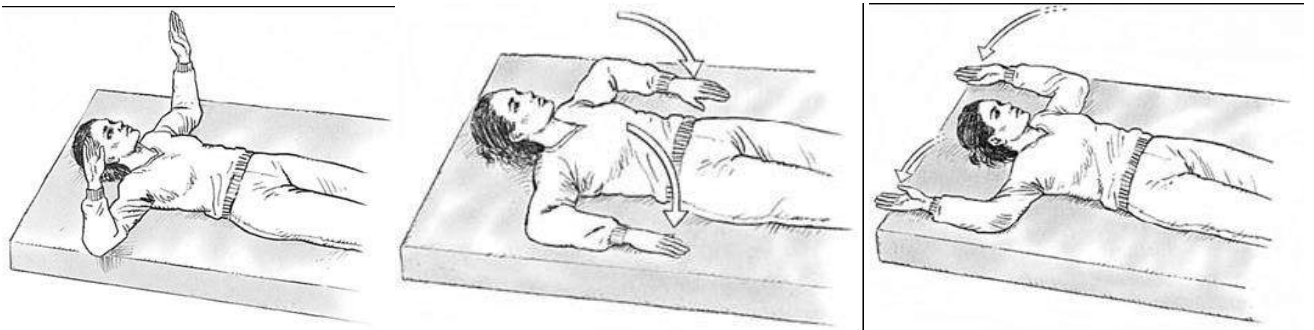
The elbows**exercise 6**

- a *Sitting up, arms stretched, pointing slightly sideways. Turn palms forward.
- b * Fold elbows till the hands touch the shoulders s.
- c * Return to start position.

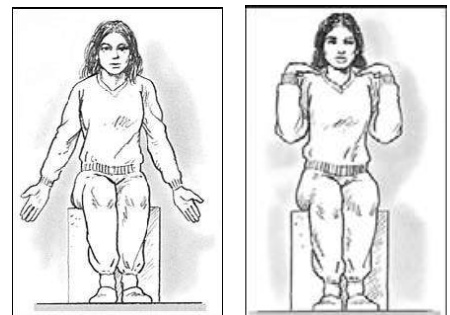

exercise 7

- a * Sitting up, arms pressed against the chest, fold the elbows 90 ° and facing outwards, the palms facing up.
- b * Turn palms downwards, while the arms remain lean against the chest.
- c * Return to start position.

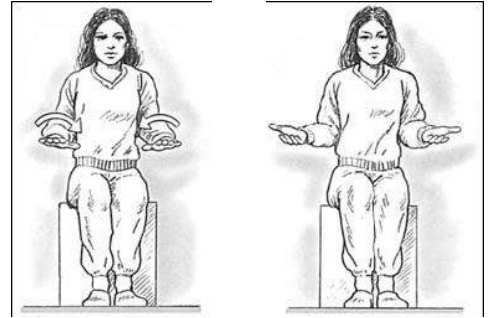
The wrists**exercise 8**

- a * Grasp with the left hand the right forearm, right above the wrist, keep the right palm downwards..
- b * Move the right hand upward as high as possible..
- c * Bent right wrist, lower hand
- d * Move hand in the direction of the thumb.
- e * Move hand in the direction of the pink.
- f * Return to start position..
- g * Repeat the same exercise with the other hand.

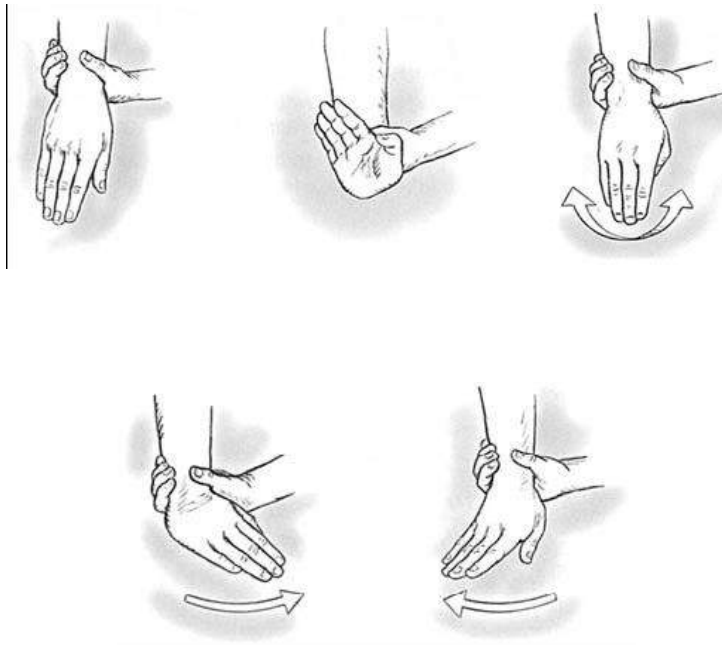

The fingers

exercise 9

- a * Hold the opened right hand facing upwards
- b * Close the hand, if needed assist with the left hand.
- c * Return to start position.
- d * Repeat exercise with the left hand.

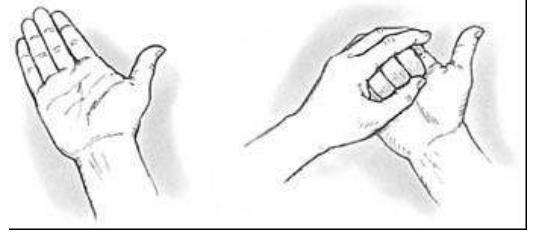

exercise 10

- a * Hold the opened right hand facing upwards.
- b * Touch tip of thumb with tip of index finger.
- c * Return to start position
- d * Resume exercise with thumb and other fingers.
- e * Repeat whole exercise with left hand.

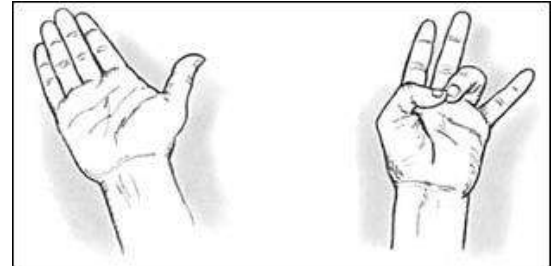

exercise 11

- a * Hold right wrist with left hand, keep opened right hand facing upward, thumb stretched outwards.
- b * Turn thumb counter clockwise. direction
- c * Turn thumb in clockwise direction.
- d * Repeat exercise with left hand.

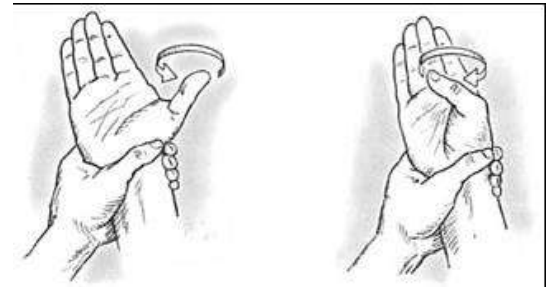

The hips

exercise 12

- a * Sitting up, feet on the ground.
- b * Lift up right tight, keeping knee bent.
- c * Return to start position
- d * Repeat exercise with left leg.

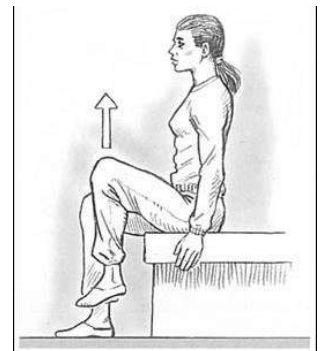

exercise 13

- a * Lying down, bent left leg, stretch out right leg
- b * Stretch right leg sideways.
- c * Return to start position.
- d * Repeat exercise with other leg.

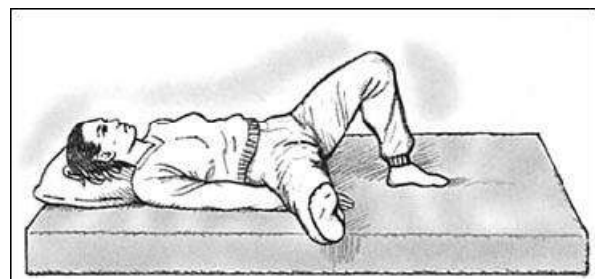
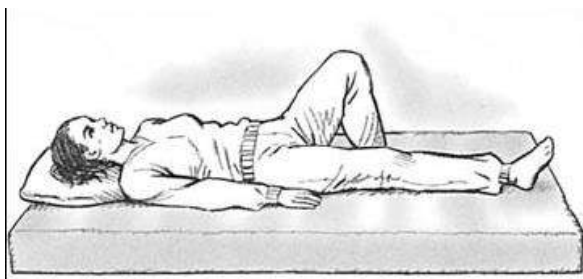

exercise 14

- a * Lying down with curved legs.
- b * Lift up the right leg..
- c * Turn the right leg until the foot is above the left leg.(the right knee will be curved outwards, with the foot sole facing downwards).
- d * Turn right leg in the other direction (the right knee bending inwards, the foot will be facing outward).
- e * Repeat exercise repeat with other leg.

The knees**exercise 15**

- a * Sitting up, legs hanging loose.
- b * Stretch the right knee.
- c * Return to start position
- d * Repeat exercise with other leg.

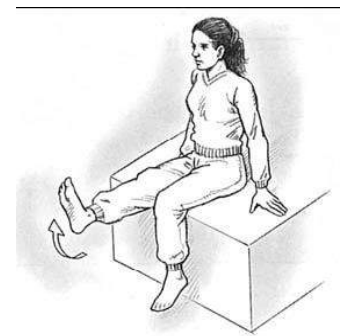
**exercise 16**

- a* Lying down, bent one leg, stretch the other leg.
- b * Lift up the stretched leg by bending knee.
- c * Stretch out the leg, by moving the foot upward.
- d * Return to original position.
- e * Repeat exercise with other leg.

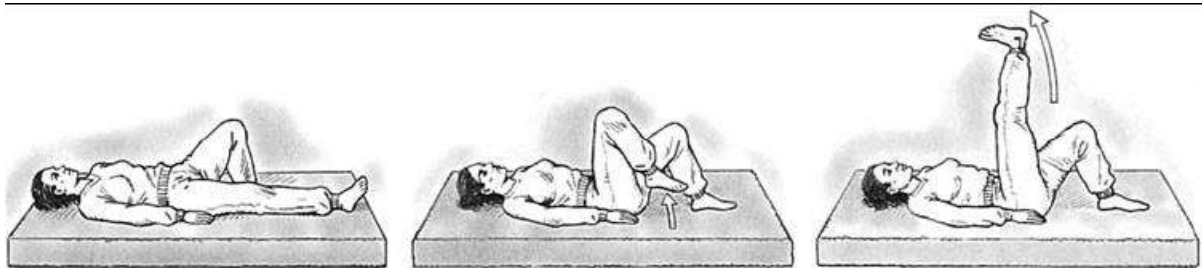

The ankles

exercise 17

a * Lying down, bent left leg, stretch out right leg (exercise can be done sitting up, then without support of the legs).

b * Stretch the toes of the right foot towards you.

c * Stretch the toes of the right foot out downwards..

d * Bend stretched foot inward, then bend the stretched foot outward..

e * Return to start position

Repeat f * Exercise with other leg.

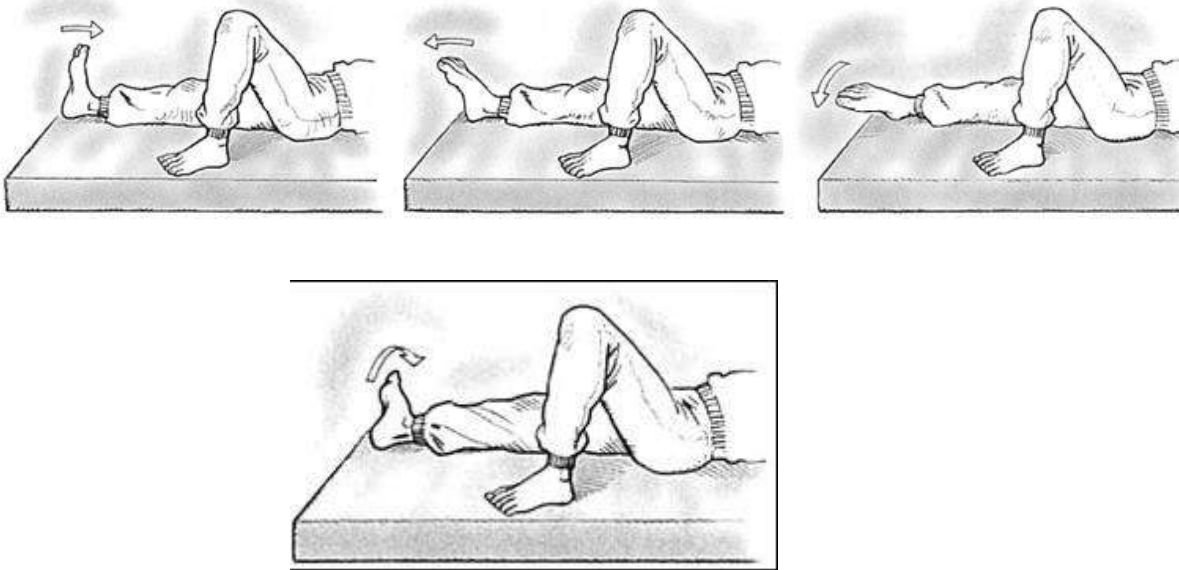

The head

exercise 18

a * Sitting up, feet on the ground

b * Bow the head with chin toward the chest, mouth closed

c * Bring head backwards again.

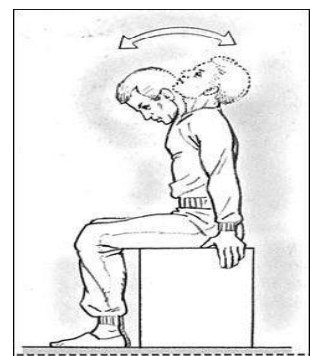

exercise 19

a * Sitting up, feet on the ground

b * Turn the head slowly and alternately from left to right.

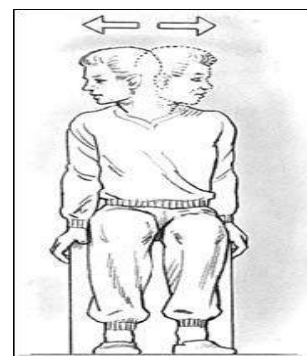

exercise 20

- a * Sitting up, feet on the ground
- b * Stretch the head alternately, so the ears tend to touch the shoulders.

**exercise 21**

- a * Sitting up, feet on the ground
- b * Start from bended head position, slowly make a circular motion, alternately from left to right. (Eyes closed, is recommended to avoid dizziness).

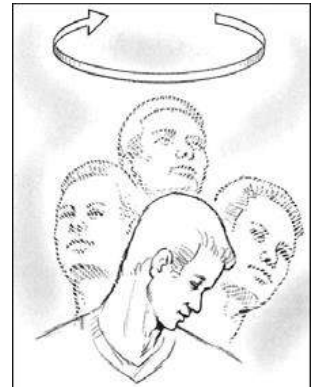
The Chest**exercise 22**

- a * Lying on your back.
- b * Bend the upper body forward so the tips of the fingers touching the feet
- c * Return to start position.

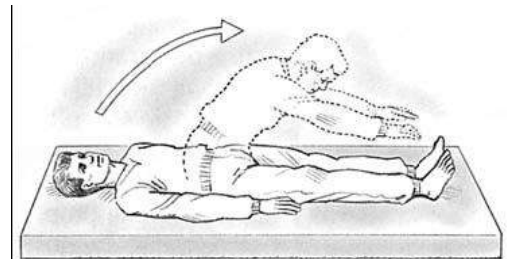
**exercise 23**

- a * Lying on your back,
- b * Bend the knees while keeping the feet on the ground.
- c * Lift the hips off the ground to create a bridge.
- d * Return to start position.

**exercise 24**

- a * Lying on your back.
 - b * Bend the knees while keeping the feet on the ground.
 - c * Spread out the arms sideways, with the palms facing down.
 - d * Pull up the knees towards the chest, then turn the knees alternately from outside to inside.
- The shoulders remain on the ground

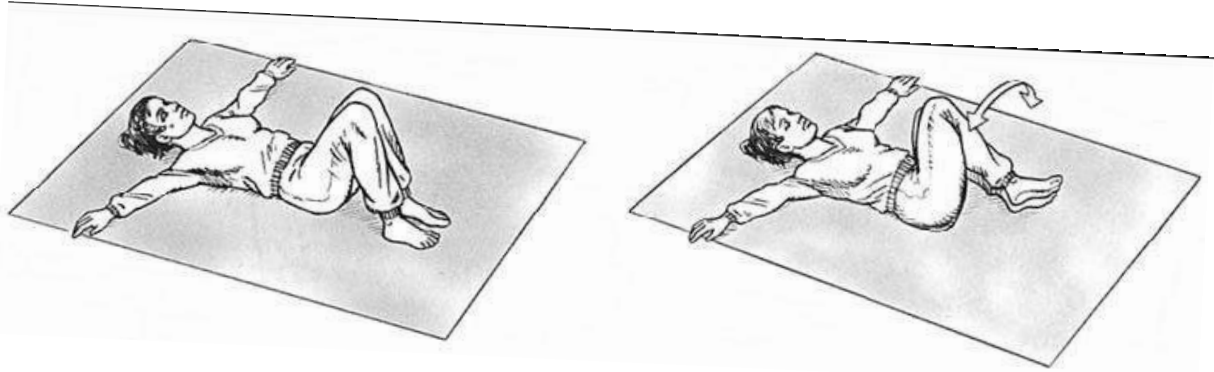

Active, assisted and passive movements

How to proceed?

This program is designated when the muscle dystonia doesn't allow an autonomous implementation of the previous exercises no more. In this case, it is necessary that another person assists when performing the exercises, which would be incomplete without the help. If the ALS patient cannot perform the exercises himself, this way he'll often retains the ability of getting a certain level of movement. If so, the helper has to move the body parts of the patient for him/her, and ask for his/her cooperation in such. (e.g. if the patient's able to contract the shoulder muscles but is too weak to lift up the arm, the helper will initiate the exercise and let the patient cooperate) Pain and fatigue should be avoided at all case.

If joint stiffness has occurred, it can be perceived by the resistance encountered when performing the movement. Therefore the helper has to act carefully and slowly, but also put a little pressure to enhance the stretching of the muscles, which should help the progressive recovery of the joint motion. Of course, one must interrupt when pain occurs.

The shoulders

exercise 1

The patient lies on back with arms stretched alongside the body.

- a * Support the left shoulder with one hand, hold the left wrist with the other hand.
- b * Lift up the stretched left arm, palm facing downwards.
- c * Move the wrist up as far as possible without causing pain
- d * Return to the start position.
- e * Repeat the exercise with the right shoulder.

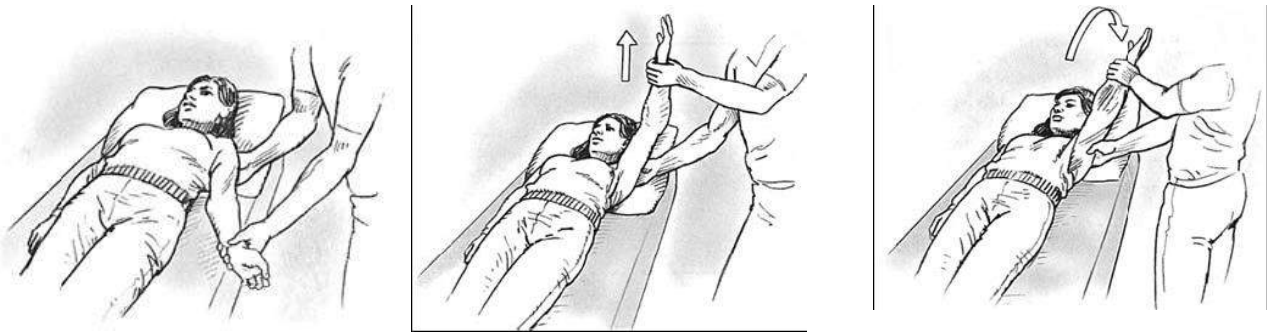

exercise 2

The patient lies on back with arms stretched alongside the body..

- a * Support the left shoulder with one hand, hold the left wrist with the other hand
- b * Stretch the left arm outward with palm facing up
- c * Move the stretched arm further till next to the head.
- d * Move the stretched arm in the opposite direction back to the start position.
- e * Repeat the exercise with the right shoulder and arm.

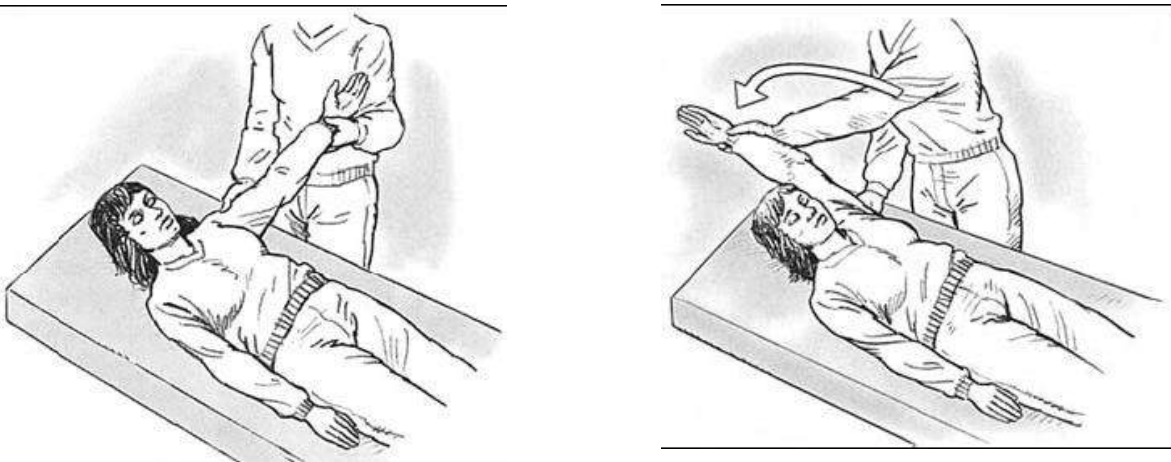

exercise 3

The patient is lying down, left arm turned outwards at 90 °. The elbow is also bent to 90 °, the palm is turned forward.

- a * Hold the left elbow with one hand, and the left wrist with the other hand.
- b * Bring the forearm forward onto the bed.
- c * Bring the forearm as far back as possible
- d * Be careful! This exercise could be painful, so be caution. Do not persist when the patient complains of pain.

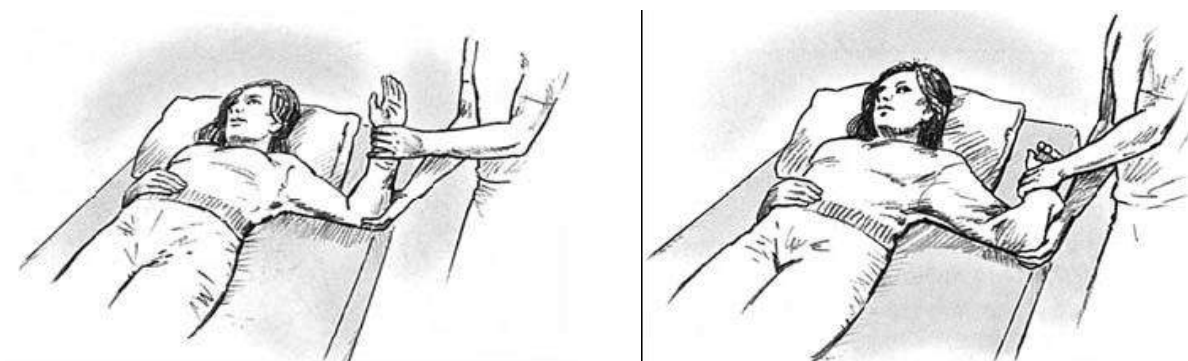

The elbows

exercise 4

The patient lies on back, with arms stretched alongside the body..

- a * Hold the left wrist
- b * Bring the left hand up to the left shoulder.
- c * Return to start position
- d * Repeat exercise with the right hand.

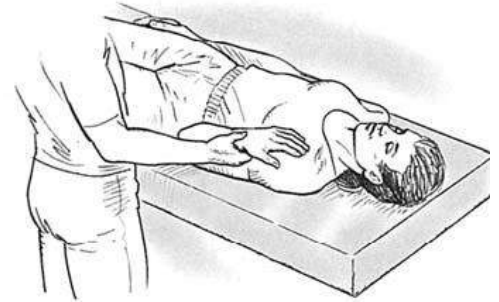

exercise 5

The patient lies on back, the left arm turned outward, the elbow bent at 90 °.

- a * Hold the left wrist with one hand and take the elbow with the other.
- b * Turn with the left forearm clockwise. The palm turns inwards.
- c * Turn in the opposite direction, the palm is facing out.
- d * Repeat the exercise with the right forearm

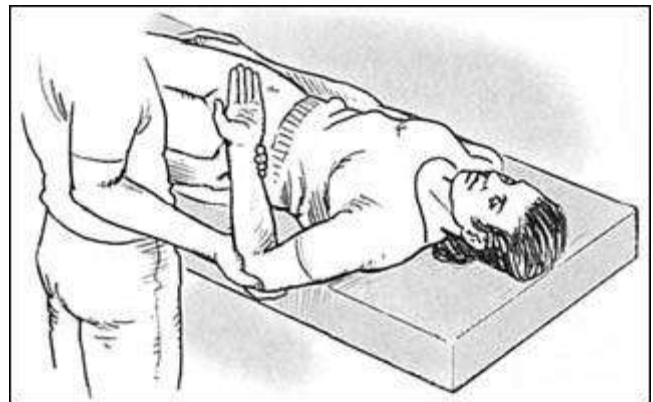
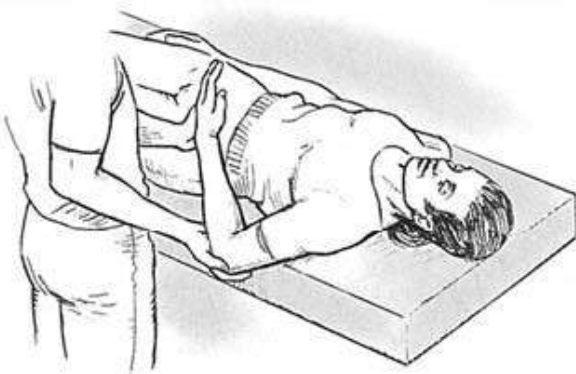

The wrists

exercise 6

- a* Hold the right wrist with one hand and the fingers with the other hand..
- b* Turn the palm upwards
- c* Turn the palm downwards
- d* Direct the hand towards the thumb
- e* Direct the hand to the little finger.
- f* Repeat the exercise with the left wrist.



The fingers

exercise 7

- a* Hold the left wrist with one hand and the fingertips with the other hand.
- b* Close the left hand, by bending the fingers.
- c* Repeat the exercise with the right hand

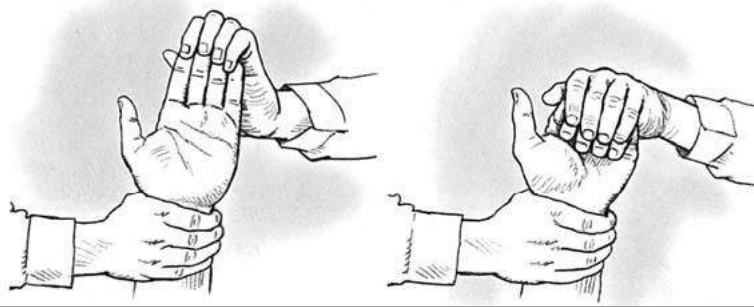

exercise 8

- a* With the palm facing upward, turn each finger flexion and extension.
- b* Repeat exercise with all fingers.
- c* Repeat exercise with other hand.

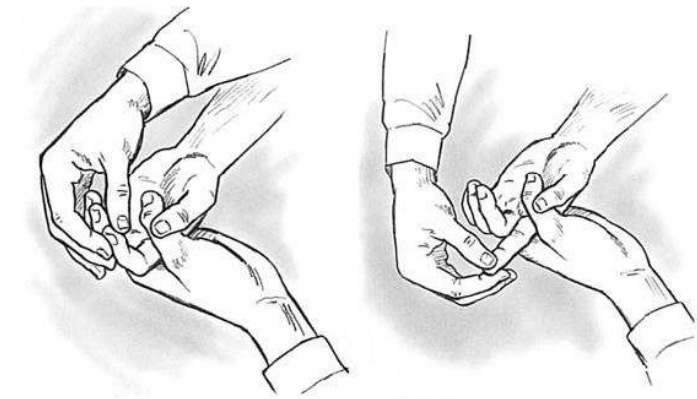

exercise 9

- a* Spread with both hands alternately the fingers of the patient's hands.
- b* Bring the fingers back into original position.

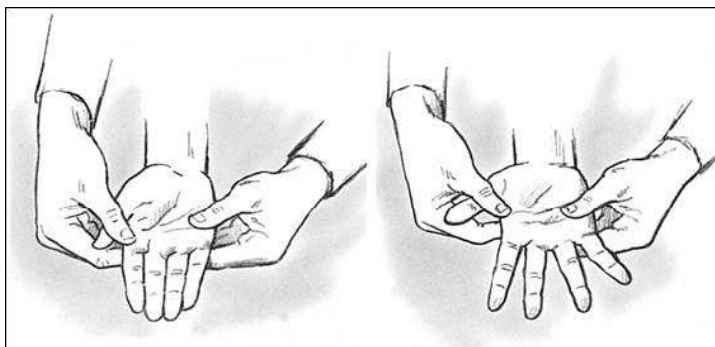

Exercise 10

- a* Hold the left hand and with one hand and take four fingers with the other hand
- b* Close the left hand till the tip of the thumb touches the index finger.
- c* Return to start position.
- d* Repeat the exercise with the tip of the thumb and the other fingers.
- e* repeat the exercise with the other hand.

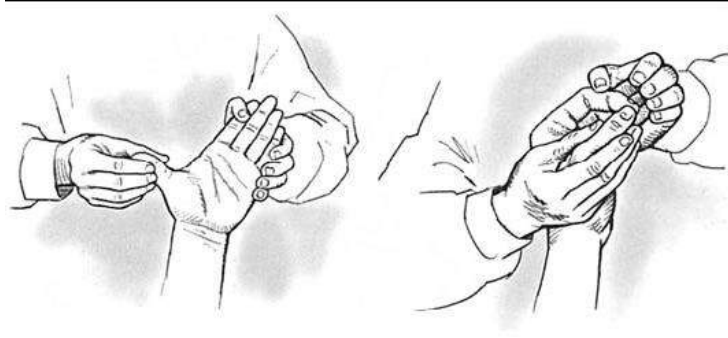
**exercise 11**

- a* Take, in one hand, the thumb of the left hand, and hold the fingers with the other hand.
- b*. Bring the thumb to the base of the little finger.
- c* Return to the start position.
- d* Repeat exercise with the thumb of the right hand.

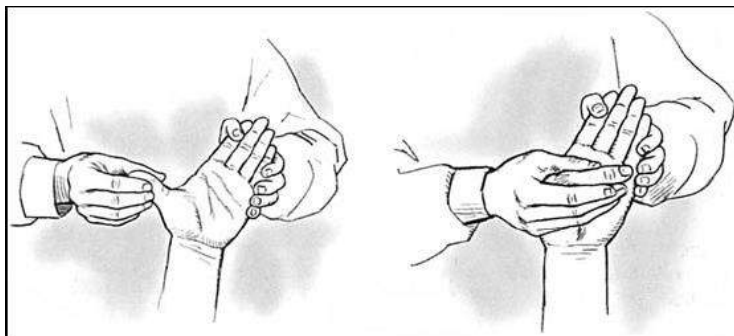
The hips**exercise 12**

- a* The patient lies on back, with stretched legs slightly spread.
- b*Support, with one hand, the back of the left knee, hold the heel with the other hand.
- c* Bring up the thigh, and bent the knee.
- d*Push the bent knee towards the chest.
- e* Repeat exercise with the right leg.

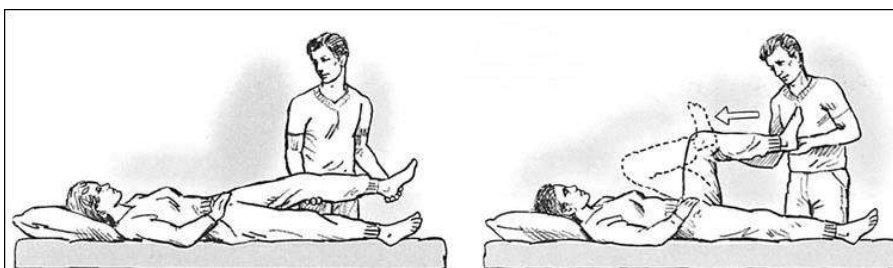

exercise 13

- a* Patient lies on back, legs straight and slightly spread.
- b* Hold the left heel with one hand, support the knee with the other hand.
- c* Bring the stretched leg slowly outward.
- d* Return slowly to the start position.
- e* Repeat exercise with other leg.

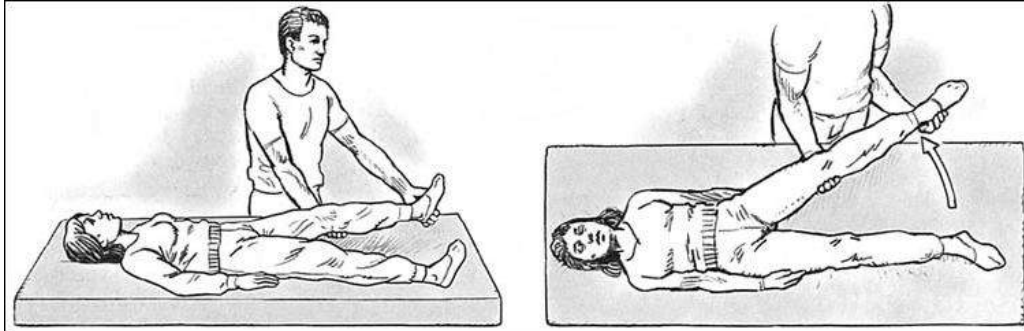
**exercise 14**

- a* Patient lies on back, legs straight and slightly spread
- b* Hold the left heel with one hand, support the knee with the other hand.
- c* lift up the left thigh, the knee remains bent.
- d* Lead the knee joint to a maximum motion, without causing pain to the patient..
- e* Return to the start position.
- f* Repeat the exercise with the tight leg..

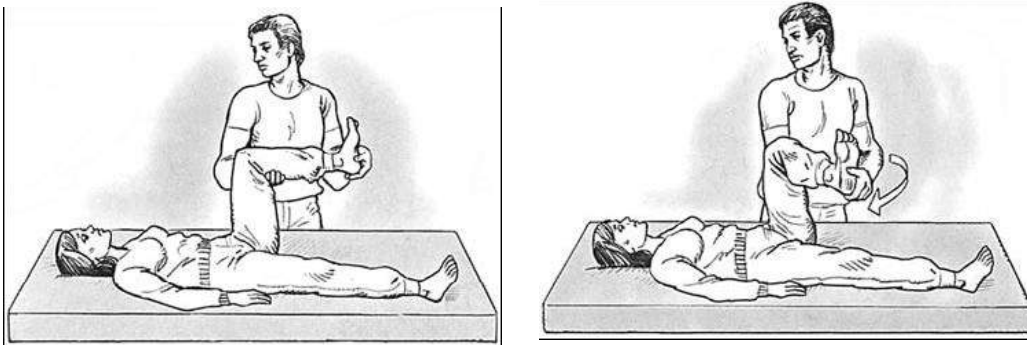
**exercise 15**

- a* Patient lies on back, leg thigh is upwards, knee is bent
- b* Hold the left heel with one hand, support the knee with the other hand.
- c* Move the left foot slowly towards the right, the knee leg, knee facing outwards.
- d* Bring the left foot slowly outwards, the knee facing inward.
- e* Repeat exercise with other leg.. Careful, do not insist.

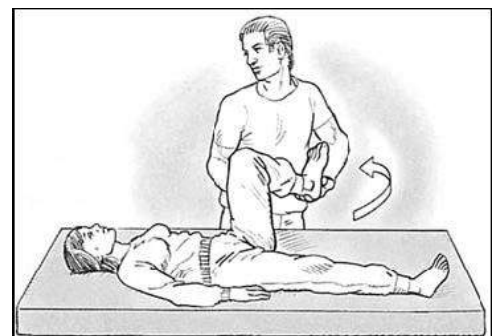

The feet

exercise 16`

- a* Patient lies on back, legs straight and slightly spread
- b* Hold the left heel with one hand, hold the leg just above the knee with the other hand.
- c* Push the tips of the toes as far as possible forward, without causing pain.
- d* Repeat exercise with other foot.

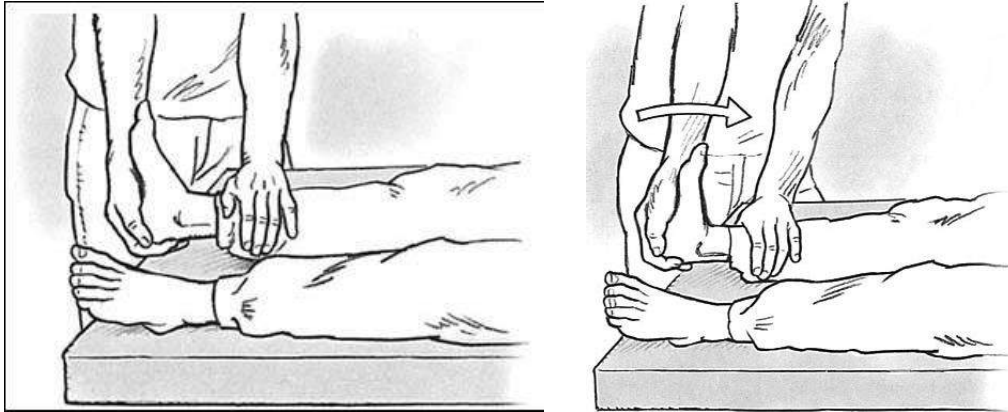

Exercise 17

- a* Turn the sole of the foot inwards and outwards.
- b* Turn the foot clockwise and counter clockwise

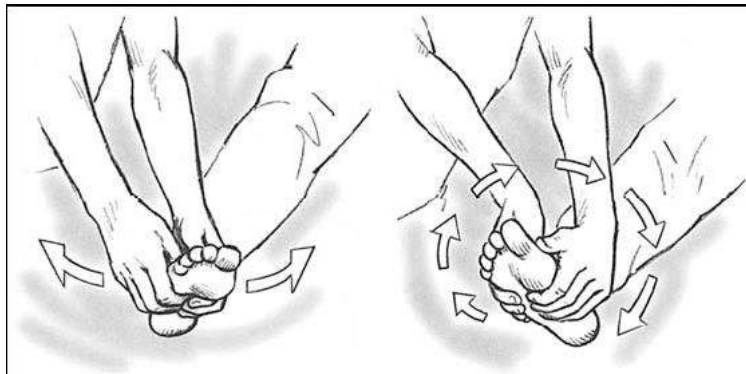

Exercise 18

Bent and stretch the toes.

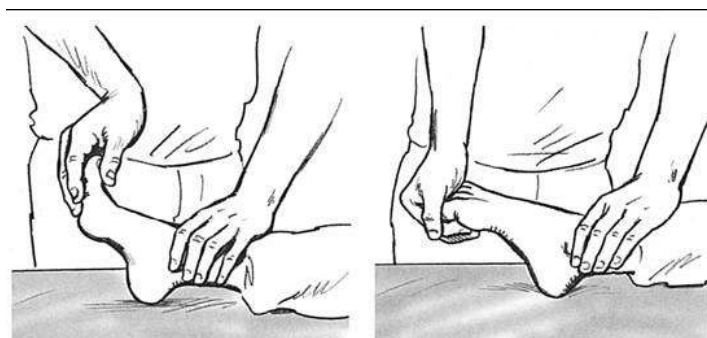

The head

Exercise 19

- a* The patient lies on back.
- b* Lift up the head slightly with one hand, put the other hand under the chin.
- c* Turn the head from left to right en vice versa

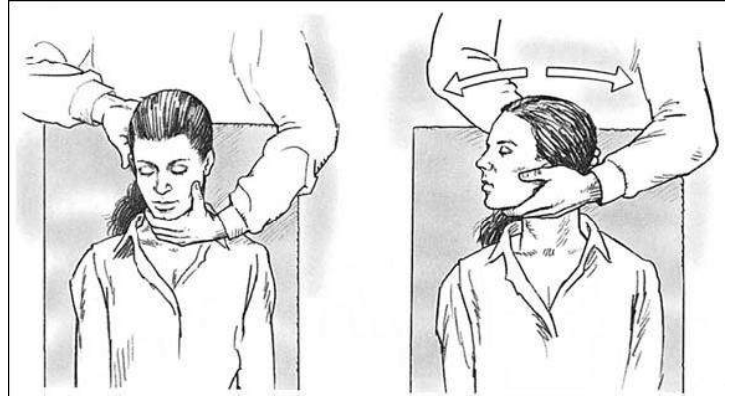

exercise 20

- a* Patient lies on back.
- b* Lift up the head, with a hand as support in the neck.
- c* Bent the head, with one hand under the chin, from left to right and back in direction of the shoulders.

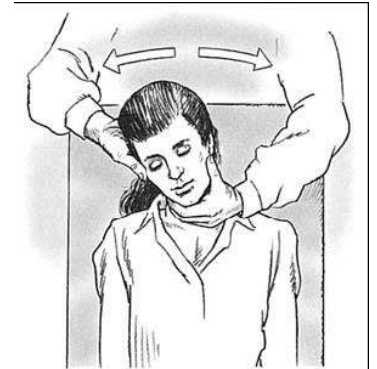

The Chest

exercise 21

- a* Patient is sitting up, with back against wall, legs are slightly spread.
- b* The helper sits in between the legs.
- c* Hold the patient laterally fixed at the shoulders, move the chest forward at the height of the shoulder blade without pulling on the arms.

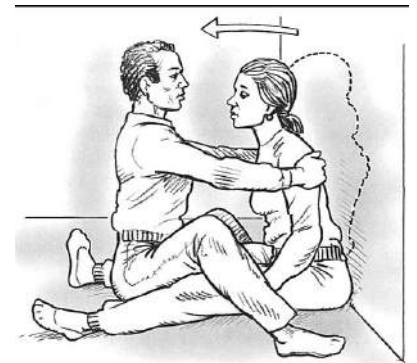

exercise 22

- a* Patient lies on back.
- b* The legs are bent in the direction of the chest
- c* Turn the legs from left to right. The shoulders remain motionless on the bed.

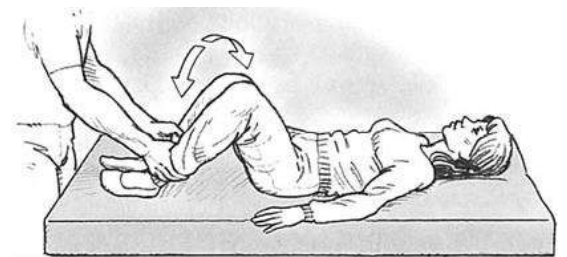

Mouth and Facial mobility.

If the muscle weakening makes movement of lips and tongue difficult, lip and tongue gymnastics useful:

- * Express the syllables 'pa' and 'ta', followed by the letters 'a' en 'u' in a rhythmic way ten times in succession.
- * Move the tongue rhythmically outwards and inward.
- * Move the tongue rhythmically from left to right and vice versa and from up towards the nose to down towards the chin.
- * Move the tongue, with open mouth, from the palate downwards.
- * Bring lips together and move them from left to right and vice versa.
- * Place the upper lip over the lower lip and vice versa.
- * Try to smile
- * Make kiss motions
- * Inflate the cheeks, without letting air escape.
- * Alternately inflate the left and right cheek.
- * Turn the chin around, from left to right and from up to down and vice versa.

The right posture

The following means are recommended to fight the fatigue of the spine.

- * Find a **support** for the head, when the patient is sitting down. E.g. a high back seat, or a wheelchair with a headrest
- * Use a **soft neck brace** when standing up.
- * While standing up wear a **shoulder brace** to reduce the weight of the arms.

How to discourage the contraction of the muscles at the back of the legs?

When standing, have a triangular block under the foot sole for a few minutes, which can prevent the contraction of the muscle tendon of the rear leg just above the ankle (Achilles tendon).

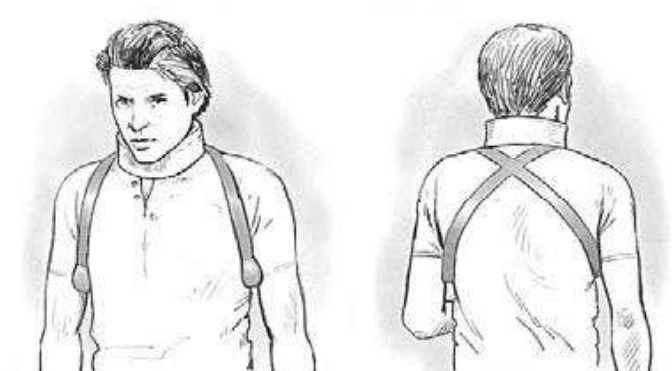

How can one, when sitting down, have a correct and comfortable posture?

The often seated patient may very well use the following instructions:

- * Sit straight up; rest the arms on a removable plate in front of you that can be mounted on the wheelchair, to support the shoulders.
- * As the headrest, one can easily use supports on the sides of the upper body
- * In seated position, the thighs can rest balanced if they are slightly spread.
- * Place the feet flat on the floor or on the footrest of the wheelchair.
- * Put a pillow between the knees while pressing the thighs tightly together.
- * If both knees are forced apart, put pads on the sides of the seat or of the wheelchair.

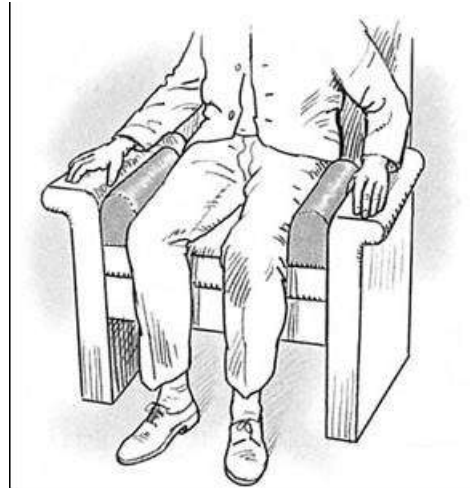

A good posture in bed can improve a relaxing sleep.

- * On the back with a roller and a pillow
- * On the side with roller and pillows

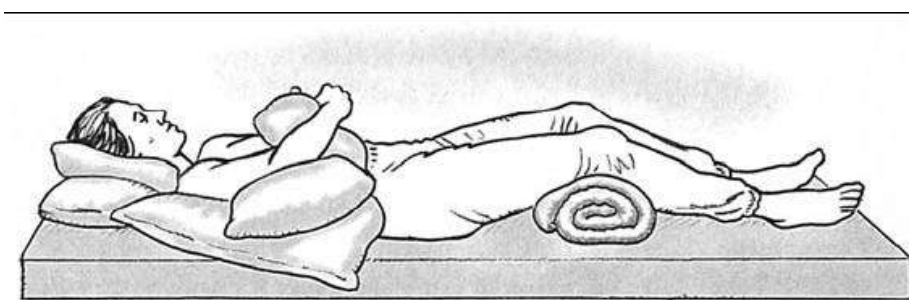
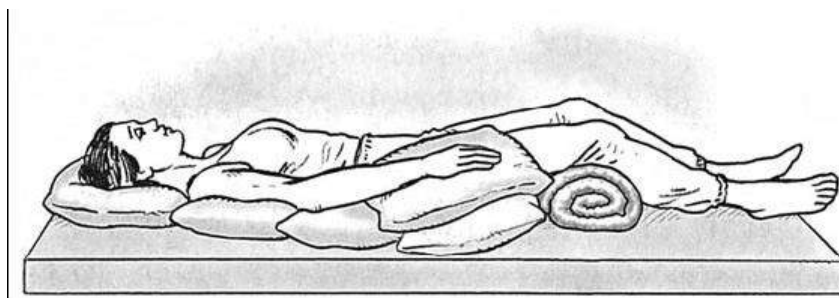

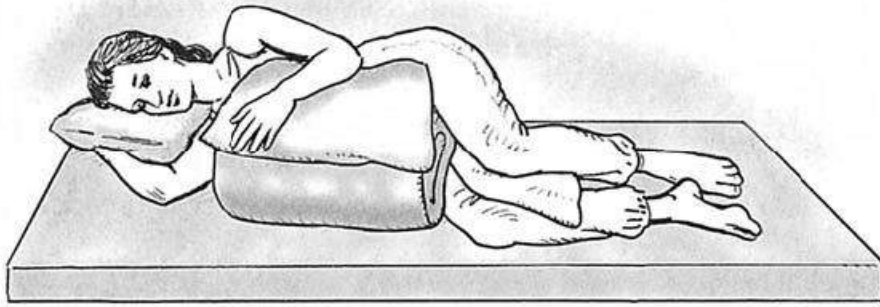

The daily life

The tools, what are they, what are they for?

All instruments that help the patient to support his daily activities are aids. A lot of activities or motions would be hard and difficult without the tools, e.g. the cane for the safety feeling when walking; the wheelchair gives more room to maneuver.

The analysis of the personal needs determines the choice of tools. On these terms we describe what we often recommended in our practice and we give, in that context, an overview of the tools for daily activities.

Walking aids and other mobility tools.

Keeping the foot flexible while walking.

An insole of CODIVILLA

When walking, the bending of the foot, in the area of the Achilles tendon, is aided. This insole is needed for the upward bending of the toes and helps the patient to avoid tripping

It is manufactured in plastic and put in the boot or high shoes.

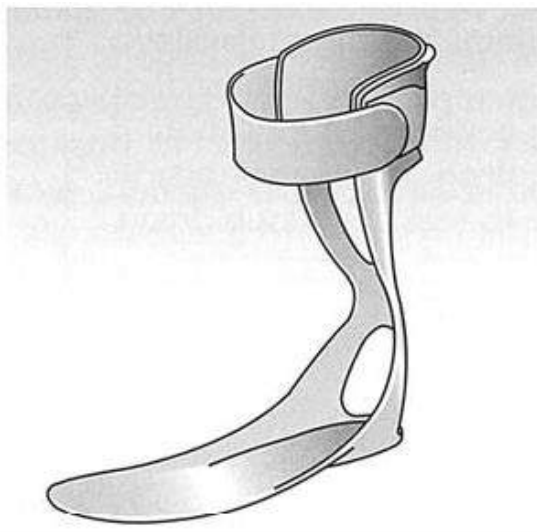

Walking sticks

They support and enhance the activities as well as the self-confidence when walking.

The elbow crutch differs from the ordinary cane through the handle as well as the support of the elbow.

Then the tripod provides a broader support base compared to the ordinary walking stick.

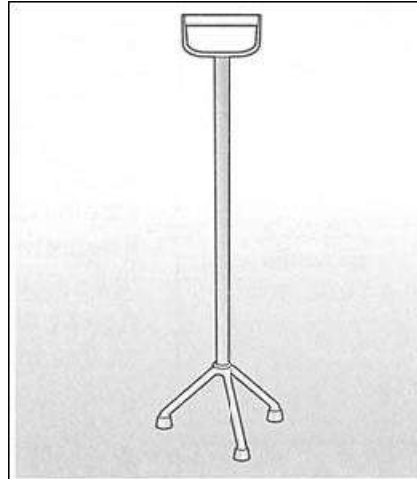

What can one use, when walking gets difficult?

The walker.

There are different models, they have a wide base and provide good support as it becomes difficult to walk.

The walker with two wheels and two fixed legs is the most commonly used. There is little danger of sliding forward when the patient is leaning on it. Because of the large size, it is not (easily) used at home.

The walker with a support for the forearms is stable and easy to push it forward.

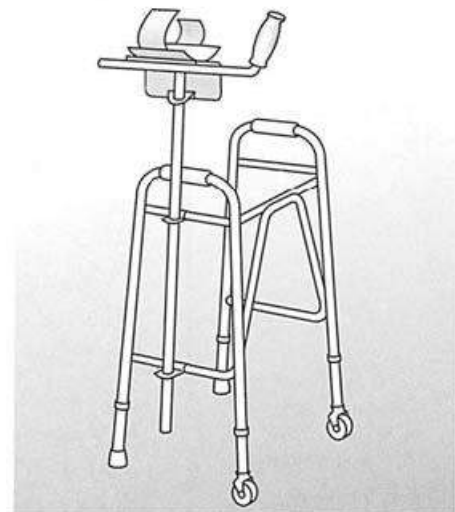

The wheelchairs.

As mobility tool, the wheelchair takes an important place. There are several kinds and models available, but it is not our intention to describe them all. We will limit our analysis to the mentioning of the characteristics which, we believe, are in the first place position if meeting the user's wishes and expectations. When prescribing a wheelchair, it has to be ensured that it is adapted to the needs of the patient.

We can distinguish two kinds of wheelchairs: collapsible ones and non-collapsible. The collapsible wheelchair is best for outdoor use. One can easily store it and transport it, it doesn't require much space.

The non-folding wheelchair is mainly to be used in the home, it takes a lot of space, and therefore difficult to transport, and its use is not easy.

If the patient will have a prolonged use of the wheelchair, it will have to provide a high level of comfort. In any case, the patient's correct measurements have to be considered when choosing the seat surface; if too big, too wide it might hamper with the blood circulation in the knee, and so causing unpleasant sensations in the lower legs.

On the other hand, a too narrow seat surface might not support to the thighs optimal. Even the backrest and footrest have to be adjusted.

An anti-decubitus pillow may be suggested.

Eventually, it's important to be able to adjust posture through easy and numerous adaptations.

This can be achieved by a movable backrest, provide with a headrest or an extension of the backrest, as well as the possibility of an adjustable footrest

A wheelchair with **adjustable system**, such as changes in seat, backrest and footrest can offer a lot of variety to facilitate the posture. The adjustability of the seating prevents the forward sliding of the patient and the lowering of the backrest offers more comfort.

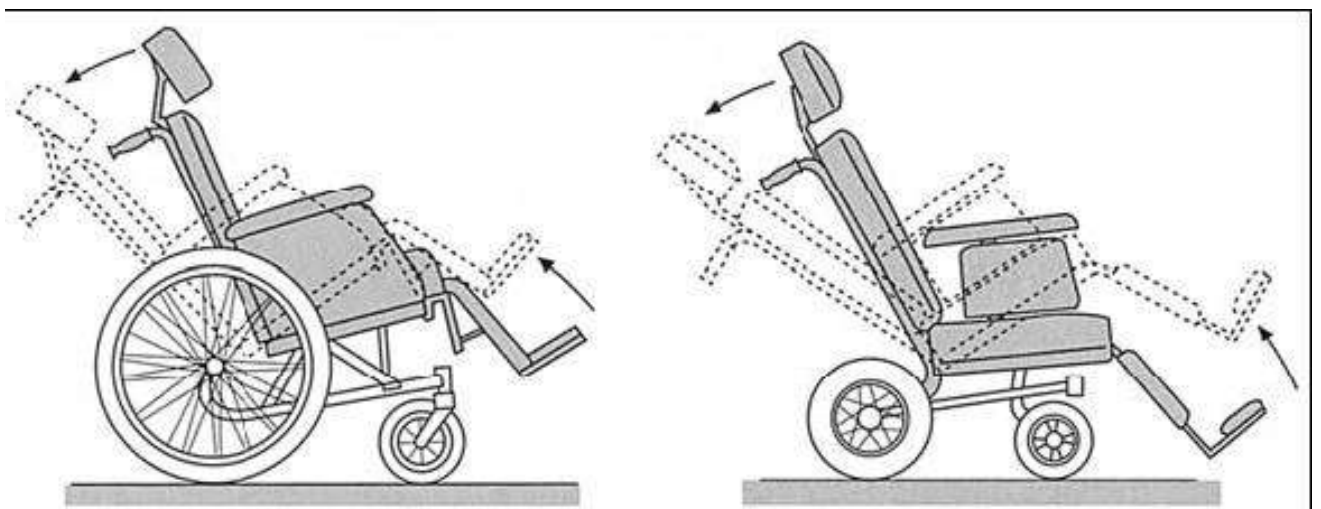

Small front wheels make the wheelchair mechanism lighter.

Removable arm- and foot supports facilitate access to a table or desk etc

Removable wheels facilitate the passage of narrow doorways etc.

When purchasing a wheelchair, one must especially take into account that it benefits the patient autonomy, and this related to the requested effort (fatigue). An **electric wheelchair** gives even more autonomy to the patient. The electronic technology provides by minimal intervention of the patient (like small finger movements, light head movement) many opportunities and facilities These wheelchairs are available in specialized stores.

Tools for the use of stairs.

In order to provide more security and safety when using the stairs, an additional railing, left and right, is indispensable. However with a wheelchair one can't 'take' the stairs, but an elevator is generally quick and easy to use. It is often impossible to install elevators in older houses., which are spaces enough for wheelchair use If it's impossible to adjust the infrastructure of the house, there are other options to meet the needs of the patient.; such as chair lifts, platform lifts and home lifts.

The chair lift

This helps to bridge the height levels.. By means of a rail, fixed to the wall, the chair will move upwards and downwards.

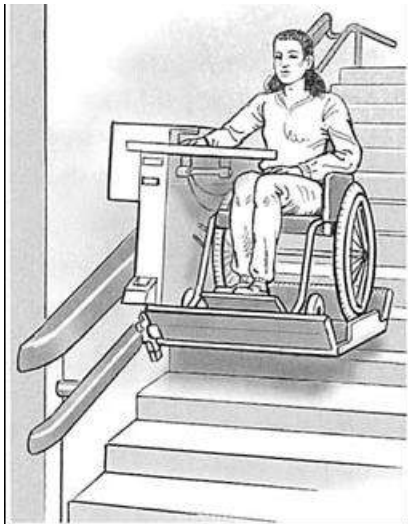

The platform lift

This works vertical up to 4 meters high, and can be compared with a regular elevator. It has a better technical and economic added value. It can be installed both indoors and outdoors.



Mobile electric servo-step, on which the wheelchair is attached to.

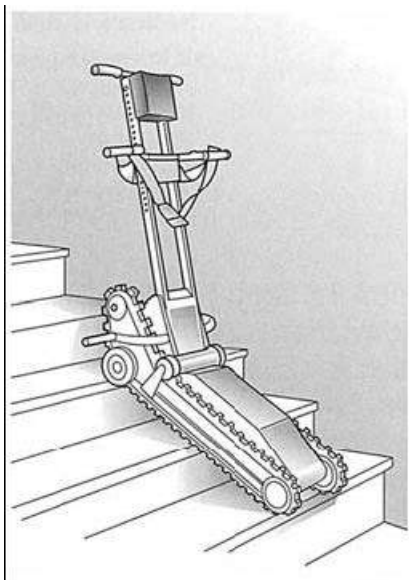

These tools have to be tested before purchasing. They mostly will be fully or partially reimbursed by the health insurance.

Changing the posture of or by the patient

The patient may have a lot of trouble and bother to come out of a chair or couch or bed. Sometimes a table or chair, or other furniture, may serve well as a support. A high chair with arm rests can be a very good solution.

If assistance is required getting up, the provider should stand right in front of the patient doing so

- He will assist to move up to the edge of the seat.
- he will support the patient's knees using his own knees.
- he will take the patient under his arms to support the chest and doing so the lifting of the pelvis will be easier and the transition will be smoother and with less trauma.

Changing position from sitting to standing.

During this movement, it is very important to not pull the arms forward, to not cause any inconvenience to the weak shoulders.

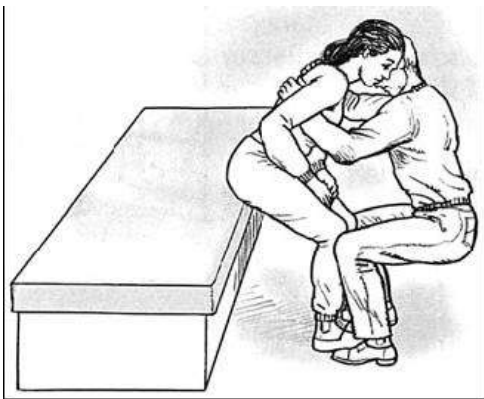

The spinning disk

The weakness and stiffness of the lower limbs can be a clog when getting up from a seat to go to the restroom or to bed. This movement can be more simply implemented by just placing the feet of the patient on a turn table. This equipment exists out of two discs mounted on top of each other that can rotate in relation to each other. Standing on this, helps the patient to rotate without having to move the feet.

The help board.

This can transfer the patient from one seat to another by means of gliding, and so avoiding an intermediary standing position. Even movements like turning in the bed, sitting and standing up can be very tricky. Lying on one side with the knees bent, can simplify the transition from lying to sitting upright. The patient's legs can easily come in or out of the bed. The helper assists with the bending of the legs, puts the legs out of bed, and supports the chest by taking him under the arms. One has to avoid pulling the arms to get them into standing position.



At bedridden

When the patient's mobility is limited, we suggest to change his position every other hour, to improve his comfort, and to alternate, as often as possible, the lying position to avoid muscle tendon contractions and pressure sores.

The orthopedic bed

This kind of bed is wider than usual and is provided with a mechanism in order to lift the head and to change the bending of the lower limbs.. It gives opportunities to apply lying variations. The intervention of housemates is limited and a pile of pillows is unnecessary. An anti-decubitus mattress (against the bed sores) can increase the comfort.

The lifter

When moving from bed to wheelchair or toilet gets extremely difficult for patient and helper both, we recommend to use the mobile lifter adapted to the circumstances. These devices can be manually or electronically operated. They are equipped with a fixture that holds the body and supports the head. When purchasing such device, one must take into account the simple monitoring, the restriction of the working space and the comfort it must provide to the patient. In order to ensure the stability of the manually operated device, the base can be adjusted and expanded. The lifter is used to move the patient from the bed to the wheelchair or the toilet. All folded up, it occupies a minimum space.

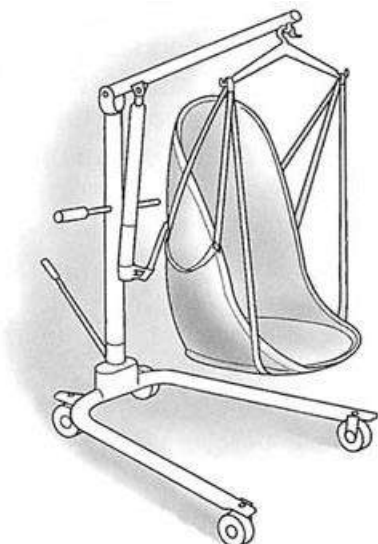

Devices for the bathrooms

Usually the bathroom is, architectural viewed, a critical space in the house. Small area, low level toilet, to high sink, difficult access into the shower, and in particular the issue of getting in and out of the bathtub

Placing brackets around the sink, foot bath, toilet, bathtub or shower facilitate the safe use of the sanitary installation.

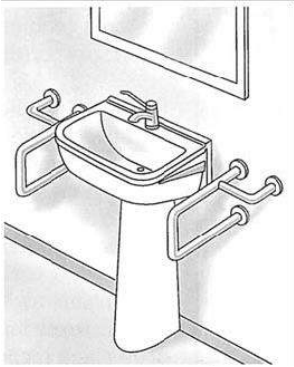

An elevated seat on the toilet facilitates the sitting down and getting up again.

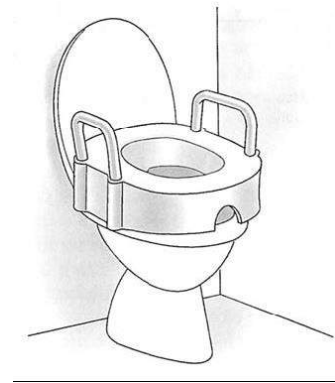

The use of the shower can be improved by the application of a chair. These are available in several sizes and types (fixed, movable, swivel, adjustable in height...)

Wall mounted folding seat

The shower is more functional when the water drainage is on the ground. Het stortbad is meer functioneel als de waterafloop aan de grond is. Because there is no threshold, one has easy access to it with a wheelchair.. A non-slip mat and a wall-mounted seat must be provided.

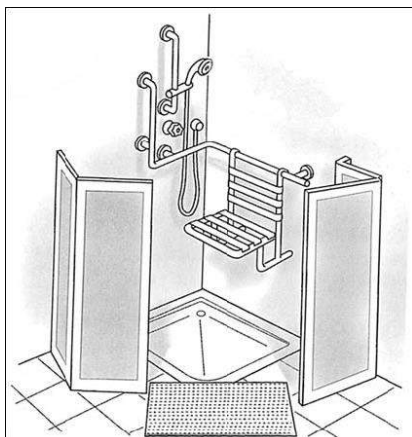

When the space of the bathtub is too small and the door passage too narrow to provide wheelchair access, or if there are thresholds, a **shower-toilet seat** or **such adjustment to the wheelchair** can be a valuable alternative.

Devices for feeding and dressing

If the hands have become less sensitive and flexible, it can affect the grabbing of cutlery or drinking glass problematically. Similarly the shirt buttoning, using a zipper and fasten shoelaces. Simple devices can be provided

- * apply a thickening around the cutlery handles
- * Use a glass with a foot.
- * replace buttons by velcro or snaps.
- * Attach a ring to a zipper
- * Use practical shoes without laces.

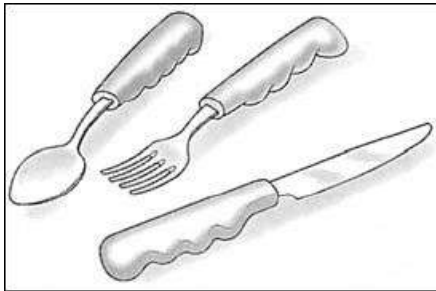

Devices when communicating.

Communication is highly important in life. It is necessary in practical action, but also in connection with the mental, emotional life and with the expression of one's thoughts and opinions.

The expression of his personal thoughts characterizes man in his family and social environment. When verbal communication has become possible or impossible, then the technical and instrumental surrogates are important in the readaptation process.

There are many means of communication, simple and complex, high technology products and crafts, even homemade.. They are all useful and efficient if adjusted to the moment and place of use. It varies from computer for communication and environmental control to Velcro around a pen for holding it..

An easy to establish instrument, made out of paper and user-friendly, is the **translucent screen**. It concerns a copying paper, to which letters, words, symbols or icons are printed on. The sheet is placed between the patient and the caregiver. Just by moving his eyes the patient can form a word or a phrase.



The computer give more possibilities and doesn't require exercise from the person involved.. One usual uses scanned programs or other custom programs which can implement the movements of the patient and compose them into words, it is important to evaluate the possible motions to select the **switch**. There are custom transformations that are able to detect the small gestures of the hands, fingers, head, foot, knee, eyes, etc.